



«CARLO PORTE»[®]

TETRA Door Set Description



Папа Карло[®]
фабрика дверей



2023

1. General description of the collection

Collection TETRA - these are prefabricated doors with a decorative coating based on PVC-film (made in Italy).

This coating has received a European quality certificate in accordance with ISO – 9002/EN 29002, and has also passed the necessary certification in Ukraine.

It means that :

- the film is manufactured in accordance with the correct technology ;
- the shades of decor do not change from party to party ;
- A primer must be applied to the film - an additional adhesive layer for better adhesion ;
- the film surface is resistant to mechanical damage ;
- resistance to dirt and chemicals and cleaning agents ;
- high resistance to UV radiation (almost does not change color during operation);
- environmental friendliness ;
- excellent combination of visual and tactile effect.

2. Basic materials and components

Door leaf

Standing the door leaf parts are 110 mm wide and 38 mm thick.

The transverse parts of the door leaf are 110 mm wide and 35 mm thick.

The door leaf parts are made from solid MDF with a high density of 900 kg/m³ (due to its high density, fasteners hold well in it).

Upper and lower transverse elements forming together with the pillar parts, the frame of the door leaf has a straight shape (Fig. 1).

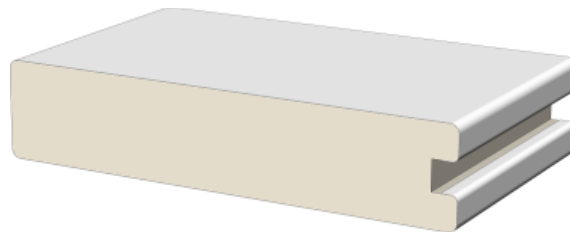
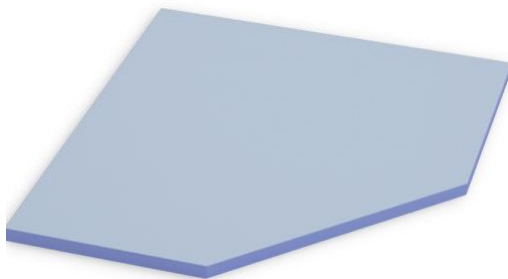
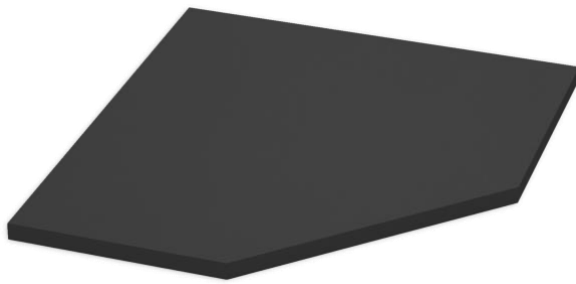

Fig.1

To obtain different door models, the following profiles and components are used:



- 2-sided satin glass 4 mm thick



- Black glass (BLK) 4 mm thick .

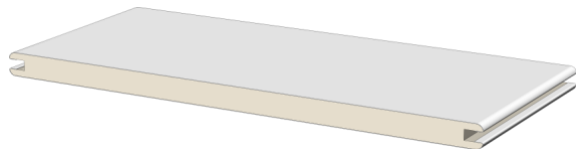

Profile delimiting

Door frame

Door blocks collection TETRA are completed coplanar door frame (Fig. 2). Door frames are made from a combination of solid wood and MDF. Door frame size 80x40 mm. It has a quarter for attaching the expander and grooves for installing the platband and seal. When ordering doors with one-sided platband, you must take into account that there remains a visible groove that must be closed with a slope or finishing (tiles, wallpaper , etc.).

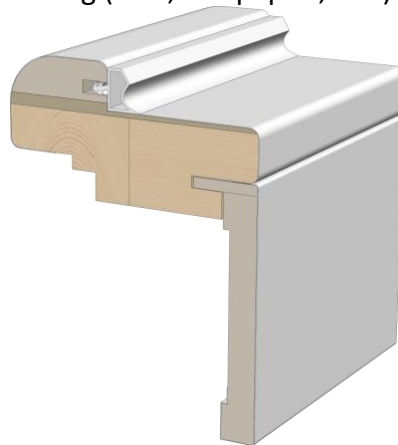

rice . 2

There is a seal installed around the perimeter of the door frame. All fasteners used to mount the door block must be hidden under the seal. It is also possible to place the fasteners in the hinge holes and in the mechanism striker .

Platbands

Door blocks are equipped with coplanar platbands measuring 75x10 mm (Fig. 3).

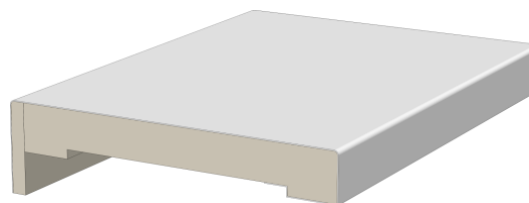

rice . 3

A special “wing” 20 mm wide facilitates installation and allows you to level out slight curvature of the walls. During installation platbands are slaughtered under 90° angle (please note this to your installers).

Expander

The expander (Fig. 4) is made in two width sizes : _

1. 100 mm – for walls up to 160 mm thick
2. 200 mm – for walls up to 260 mm thick

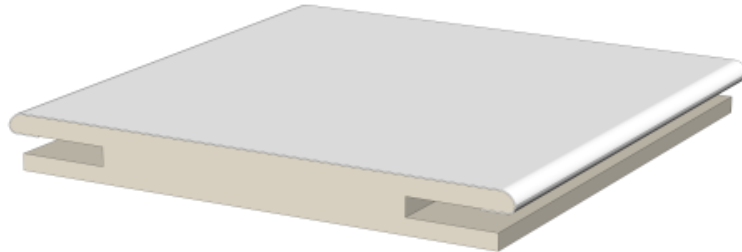

rice . 4

The expander has a groove for attaching platbands on both sides. This is done so that it can be cut into two parts and used for different door blocks if _ allows thickness walls .

With wall thickness more than 260 mm expander necessary join using a connecting H-shaped profile or a special tenon, as shown in Fig. 5.

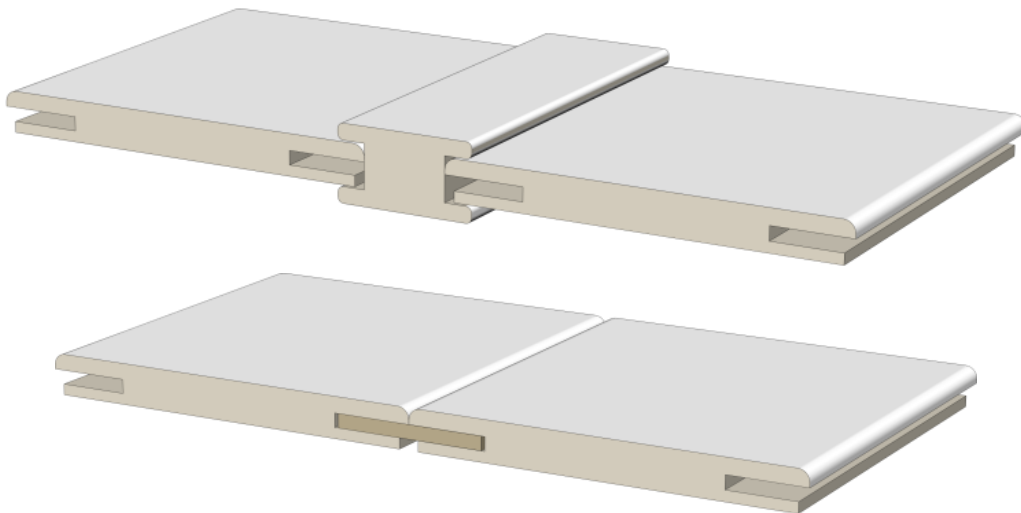

rice . 5

The expander fits into the groove of the door frame by 15-20 mm and is screwed to before installation. If necessary, the expander can be reduced in width by cutting it to width.

3. Standard dimensions door blocks

- 2030 x 670 x 80 mm (overall door leaf size : 2000 x 610 mm);
- 2030 x 770 x 80 mm (overall door leaf size : 2000 x 710 mm);
- 2030 x 870 x 80 mm (overall door leaf size : 2000 x 810 mm);
- 2030 x 970 x 80 mm (overall door leaf size : 2000 x 910 mm);

4. Wiring diagrams

Installation diagram for TETRA doors indicated in Fig. 6.

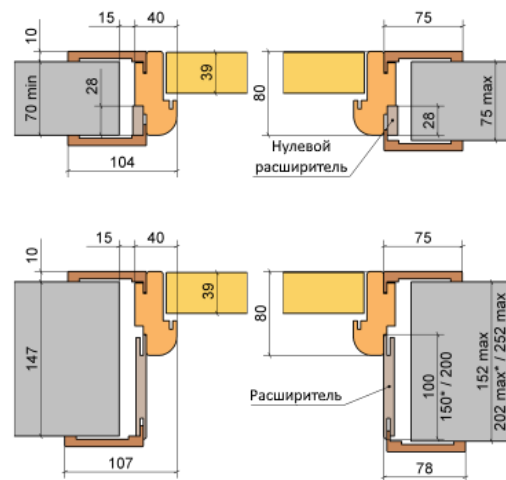

rice . 6

5. Accessories

Hinges

5.1. Overhead hinge “butterfly” RDA 100*3 mm (2 bearings) Eurocento

Note: The default setting is 3 hinge s. Color – matte chrome, black.

5.2. Invoices hinges AL143Q (Fig. 9)

Note: The default setting is 3 hinges . Color – matte chrome, white, black



5.3. Hidden hinges (by default, 2 or 3 hinges are cut in (depending on the model and size of the door leaf)). Hinge color - matte metal, black, white.



Locks

Locks are available in the following colors : nickel (AGB Evolution /AGB Polaris), black and white (AGB Polaris only).

There are 2 types of mechanisms available :

- 1) **AGB Evolution** – standard mechanism with a polyurethane “tongue”.
- 2) **AGB Polaris** – mechanism with a magnetic “ tongue ” for easy closing and silent operation.

According to the type of closure, locks are divided into: **Latch , retainer (WC) or key**
 Please note that all canvases come with one hole for a handle. Holes for clamp (WC) or secret keys are produced at the installation site .

Quality criteria for the front surfaces of doors coated with decorative films

The regulatory document regulates some features related to criteria _ quality surfaces facial doors with finishing coated decorative films (collection TETRA). Because on the territory Since Ukraine does not have separate regulatory documentation for doors with decorative film

coatings, this type of product is also subject to all requirements according to the standard DSTU B V.2.6-99:2009.

On the front surfaces of doors lined with decorative film materials, the dimensions and number of permissible deviations should not exceed those indicated in Table 1.

Table 1

No.	The name of indicators	Admission standards	Notes
1	Uneven gloss or haze: - width no more, mm - total area no more than, cm ² /m ² ,	- 5 - 5	Allowed as stripes, and in the form individual local spots
2	Scratches from mechanical damage is allowed superficial, unnoticeable* - quantity, pcs/product, not more - total length, mm/per product, no more	- 2 - 50	Allowed coloring scratches special funds for restoration
3	Dents	Not allowed	
4	Cracks with rupture of the film surface	Not allowed	
5	Foreign inclusions under film, - quantity, pcs./m ² , not more - diameter, mm, no more	- 2 - 2	Meaning foreign inclusions, caught between film and base
6	Folds	Not allowed	
7	Spots on film: - diameter, mm, no more - quantity, pcs./m ² , a little more	- 5 - 2	
8	Bloating films	Not allowed	

* - scratches whose depth is greater than the thickness of the film coating are not allowed, i.e. to the base of the product.

The quality of the surface is checked visually or using simple measuring instruments (metal ruler, tape measure, etc.).

The surface is inspected from a distance of 1000 mm, in daylight or artificial light. All specified deviations that are not visible from the specified distance cannot be the reason for refusal to accept the product.

Compliance of the external appearance of the front surfaces of doors with decorative cladding with the requirements of this document is assessed visually, without applying magnifying devices _

Permissible deviations in product geometry

Maximum deviations in the dimensions of frames of boxes and canvases door assembled blocks should not exceed the values given in Table 2.

table 2

Dimensions, mm	Value of boundary deviations, mm			
	Internal dimensions of boxes	External dimensions of boxes	External sizes canvases	Diagonal length difference
From 501 to 2000 inclusive	+ 1.5	±3.0	0 - 1.0	3.0
From 2001 to 3000 inclusive	+ 2.0	±4.0	0 - 1.5	4.0

The deviation from the plane of door blocks should be no more than 2.0 mm per 1 m in height and width (we are talking about deviations associated with bending canvases on a plane

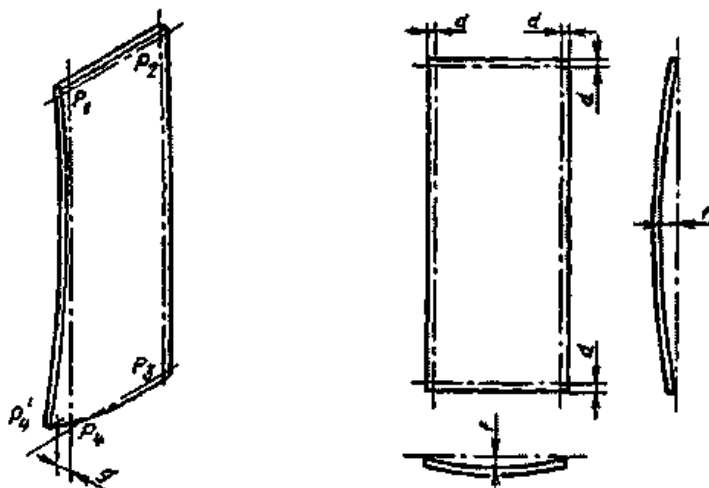

).

The deviation from the straightness of the edges of the parts must exceed 1.0 mm per 1 m of the length of any section of the door block element. (We are talking about deviations associated with the bending of the ends and edges of the canvases).

The difference in the front surfaces in corner and T-shaped joints of adjacent parts of boxes and canvases , the installation of which provided in one plane, should not exceed 1.0 mm. (We are talking about differences in standing and transverse elements when they are connected in the same plane).

Gaps in corner and T-joints larger than 0.2 mm are not allowed. (We are talking about gaps in corner joints of boxes and connections standing and transverse elements canvases).

Deviation from squareness door the blades should not exceed 2.0 mm per 1 length.

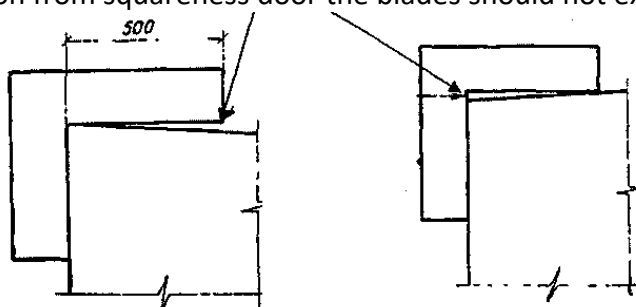

The main operational properties of door blocks are given in Table 3.



Table 3

Indicator name	Indicator value
Air permeability, m ³ /(hour • m ²), not less than:	1.5
Sound insulation, dBA, not less:	25
Reliability of mechanisms and hinges, opening cycles closing, no less than:	50,000